



# NELLY X1-D20

## MARINE GRADE DOWNLIGHT

Designed for Marine Electrical Instability

IP65 Front Rated | 80V Extended Tolerance | Zero EMI | Integrated Aluminum Driver

Thermal & High Voltage Protection | Custom Sizes & Finishes Available

### STEIN TECHNOLOGY



Automatic Thermal Regulation  
With Adaptive Power Control



Efficient heat dissipation design  
minimizes overheating and  
reduces fire risk.



EMI-Free Operation

### TECHNICAL SPECS

#### ELECTRICAL DATA

System Power	4 Watt
Nominal Operating Voltage	20-30V DC
Extended Voltage Tolerance	Up to 80V DC (temporary operation)
Energy Efficiency	Up to 98%
Dimming	PWM dimmable (compatible with 1-10V and DALI systems via suitable driver)

#### OPTICAL PERFORMANCE

Luminous Flux	480 lm
Luminous Efficacy	120 lm/W
Color Rendering Index (CRI)	≥90
Beam Angle	45°
Rated Lifetime	L70 lifetime >100,000h
Color Consistency	3-Step MacAdam Ellipse

#### PROTECTION & SAFETY

Reverse Polarity Protection	Full electronic protection
Surge Immunity	IEC transient protection compliant up to 200V (short-duration spikes)
Driver Construction	Fully integrated aluminum-housed driver (no external plastic box)
Linear Constant Current Driver	No Switching Frequency
Flicker	0% Flicker (No PWM / No High Frequency Modulation)
Ingress Protection Architecture	IP65 front exposure / IP64 ceiling cavity protection

#### THERMAL MANAGEMENT

Operating Ambient Temperature	-40°C to +60°C
Max Case Temperature	70°C
Adaptive Thermal Regulation	Continuous thermal monitoring with dynamic current adjustment
Confined-Space Thermal Stability	Stable operation in low-ventilation ceiling cavities.
Adaptive Overvoltage Thermal Regulation	Automatic current derating under extended voltage conditions

### DIMENSIONS

These dimensions can be optionally changed

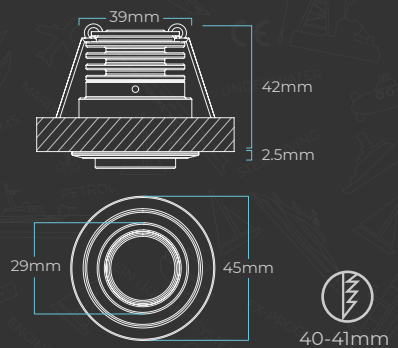

### BEAM ANGLE

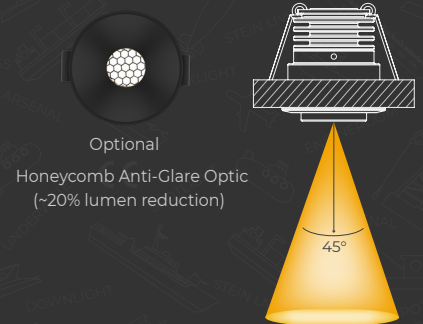

### FINISHES

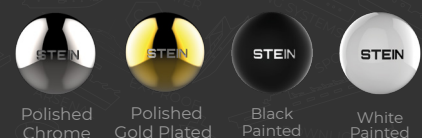

### LIGHT COLORS

