

If the standard products in the catalog do not meet your needs, you can now produce your own lamp.

Make Your Lamp

Due to its custom design, the pricing of the designed product is determined based on the standards that product aligns with, with no price difference. We offer the opportunity to design any product you may need and with STEIN's exclusive high technology and quality, we provide you with the ability to design your own products within 3-5 minutes.

How Can You Do

"Within 1-5 days, you will receive the actual image and technical specifications of the product you have designed, either by providing the measurements of the areas indicated with arrow marks in the technical drawings or by preparing a simple drawing with the dimensions and shape according to your needs."

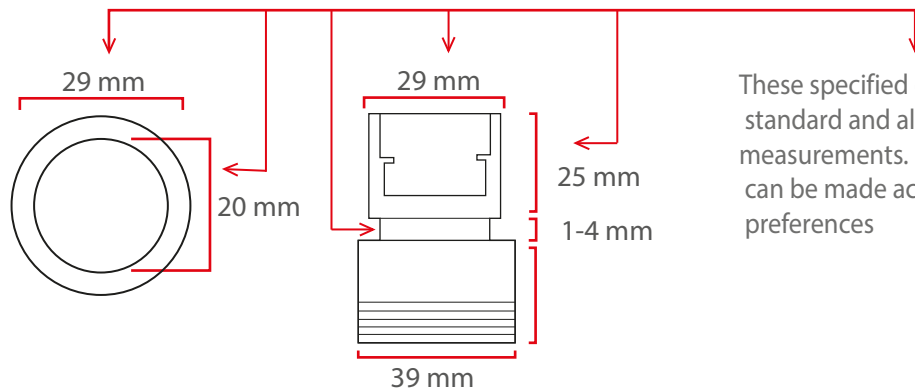

These specified dimensions are standard and also the minimum measurements. Larger dimensions can be made according to your preferences

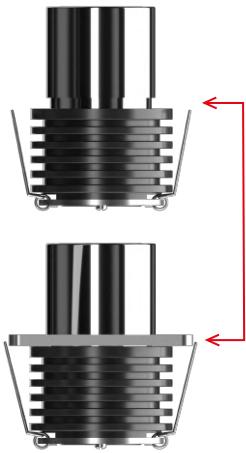

You can mount a material with a thickness of 1-4 mm by compressing it into the specified section with a hole diameter of 28.

Instead of the designs found in the catalog, you can create your own unique designs and easily assemble them by purchasing only the required quantity of lamps. You can separate the lamp's cooling and LED components by twisting them. Afterward, you can pass them through the 28 mm hole you've drilled and compress them again. If the hole you're drilling is on a plate with a width of 50-60 mm, spacing the lamps at an average of 200-300 mm intervals will be sufficient. You can use a 3mm thick aluminum plate with springs on the lamps to hold your plate on the ceiling. This way, you can create the visual designs you desire on your ceilings

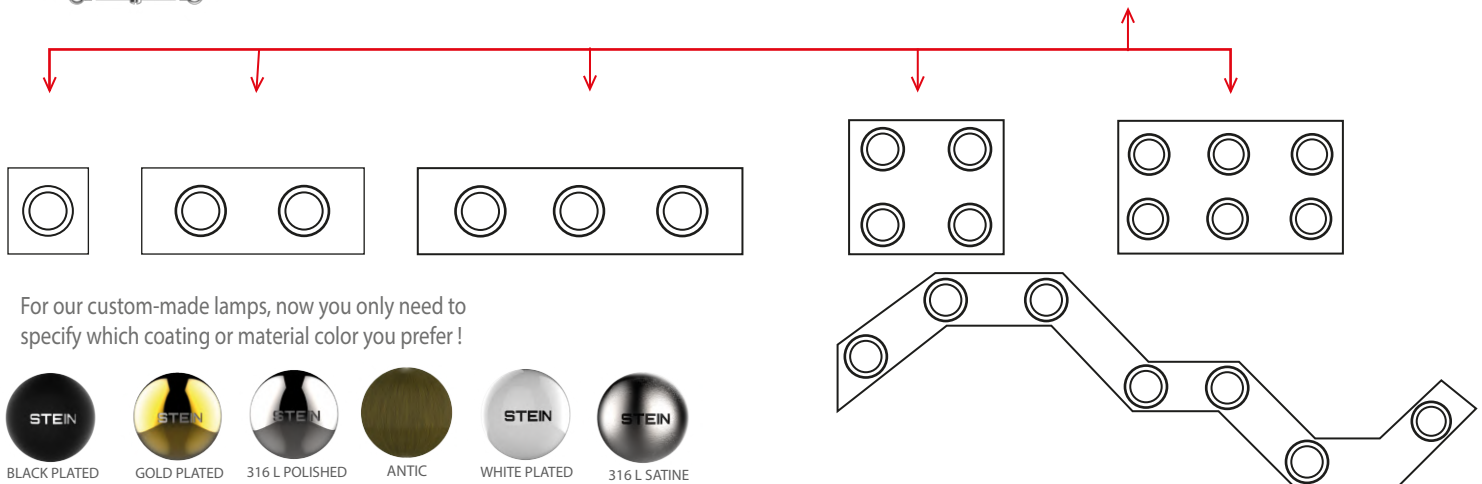

For our custom-made lamps, now you only need to specify which coating or material color you prefer !

